

INTERNATIONAL APPLICATION PUBLISHED UNDER THE PATENT COOPERATION TREATY (PCT)

<p>(51) International Patent Classification ⁶ : E04F 15/04</p>	<p>A1</p>	<p>(11) International Publication Number: WO 99/66152 (43) International Publication Date: 23 December 1999 (23.12.99)</p>
<p>(21) International Application Number: PCT/SE99/00934 (22) International Filing Date: 31 May 1999 (31.05.99) (30) Priority Data: 9801986-2 3 June 1998 (03.06.98) SE (71) Applicant (for all designated States except US): VÄLINGE ALUMINIUM AB [SE/SE]; Kyrkogränd 1, S-260 40 Viken (SE). (72) Inventor; and (75) Inventor/Applicant (for US only): PERVAN, Darko [SE/SE]; Kyrkogränd 1, S-260 40 Viken (SE). (74) Agent: AWAPATENT AB; P.O. Box 5117, S-200 17 Malmö (SE).</p>	<p>(81) Designated States: AE, AL, AM, AT, AT (Utility model), AU, AZ, BA, BB, BG, BR, BY, CA, CH, CN, CU, CZ, CZ (Utility model), DE, DE (Utility model), DK, DK (Utility model), EE, EE (Utility model), ES, FI, FI (Utility model), GB, GD, GE, GH, GM, HR, HU, ID, IL, IN, IS, JP, KE, KG, KP, KR, KZ, LC, LK, LR, LS, LT, LU, LV, MD, MG, MK, MN, MW, MX, NO, NZ, PL, PT, RO, RU, SD, SE, SG, SI, SK, SK (Utility model), SL, TJ, TM, TR, TT, UA, UG, US, UZ, VN, YU, ZA, ZW, ARIPO patent (GH, GM, KE, LS, MW, SD, SL, SZ, UG, ZW), Eurasian patent (AM, AZ, BY, KG, KZ, MD, RU, TJ, TM), European patent (AT, BE, CH, CY, DE, DK, ES, FI, FR, GB, GR, IE, IT, LU, MC, NL, PT, SE), OAPI patent (BF, BJ, CF, CG, CI, CM, GA, GN, GW, ML, MR, NE, SN, TD, TG).</p> <p>Published With international search report. Before the expiration of the time limit for amending the claims and to be republished in the event of the receipt of amendments. In English translation (filed in Swedish).</p>	

(54) Title: LOCKING SYSTEM AND FLOORING BOARD

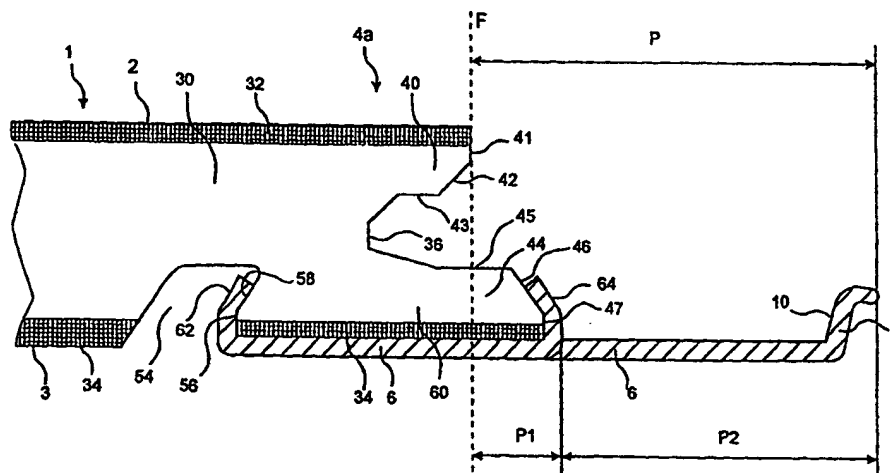

(57) Abstract

The invention relates to a locking system for mechanical joining of floorboards (1) along a vertical joint plane (F), and a floorboard comprising such a locking system. For joining perpendicular to the joint plane (F) there is a locking groove formed in the underside (3) of a first joint edge at a distance from the joint plane (F), and a portion (P) projecting from the lower part of the second joint edge (4a) and below the first joint edge and, at a distance from the joint plane (F), supporting a locking element (8) cooperating with the locking groove (14), said projecting portion (P) thus being located entirely outside the joint plane (F). The projecting portion (P) presents at least two horizontally juxtaposed parts (P1, P2), which differ from each other in respect of at least one of the parameters material composition and material properties.

FOR THE PURPOSES OF INFORMATION ONLY

Codes used to identify States party to the PCT on the front pages of pamphlets publishing international applications under the PCT.

AL	Albania	ES	Spain	LS	Lesotho	SI	Slovenia
AM	Armenia	FI	Finland	LT	Lithuania	SK	Slovakia
AT	Austria	FR	France	LU	Luxembourg	SN	Senegal
AU	Australia	GA	Gabon	LV	Latvia	SZ	Swaziland
AZ	Azerbaijan	GB	United Kingdom	MC	Monaco	TD	Chad
BA	Bosnia and Herzegovina	GE	Georgia	MD	Republic of Moldova	TG	Togo
BB	Barbados	GH	Ghana	MG	Madagascar	TJ	Tajikistan
BE	Belgium	GN	Guinea	MK	The former Yugoslav Republic of Macedonia	TM	Turkmenistan
BF	Burkina Faso	GR	Greece			TR	Turkey
BG	Bulgaria	HU	Hungary	ML	Mali	TT	Trinidad and Tobago
BJ	Benin	IE	Ireland	MN	Mongolia	UA	Ukraine
BR	Brazil	IL	Israel	MR	Mauritania	UG	Uganda
BY	Belarus	IS	Iceland	MW	Malawi	US	United States of America
CA	Canada	IT	Italy	MX	Mexico	UZ	Uzbekistan
CF	Central African Republic	JP	Japan	NE	Niger	VN	Viet Nam
CG	Congo	KE	Kenya	NL	Netherlands	YU	Yugoslavia
CH	Switzerland	KG	Kyrgyzstan	NO	Norway	ZW	Zimbabwe
CI	Côte d'Ivoire	KP	Democratic People's Republic of Korea	NZ	New Zealand		
CM	Cameroon			PL	Poland		
CN	China	KR	Republic of Korea	PT	Portugal		
CU	Cuba	KZ	Kazakstan	RO	Romania		
CZ	Czech Republic	LC	Saint Lucia	RU	Russian Federation		
DE	Germany	LI	Liechtenstein	SD	Sudan		
DK	Denmark	LK	Sri Lanka	SE	Sweden		
EE	Estonia	LR	Liberia	SG	Singapore		

LOCKING SYSTEM AND FLOORING BOARD

The invention generally relates to a locking system for providing mechanical joining of floorboards. More specifically, the invention concerns an improvement of a locking system of the type described and shown
5 in WO 94/26999. The invention also relates to a floorboard provided with such a locking system. According to one more aspect of the invention, a floorboard with different designs of the locking system on long side and short side is provided.

10

Field of the Invention

The invention is particularly suited for mechanical joining of thin floating floorboards, such as laminate and parquet flooring, and therefore the following
15 description of prior art and the objects and features of the invention will be directed to this field of application, in particular rectangular floorboards that are joined on long sides as well as short sides. The features distinguishing the invention concern in the first place
20 parts of the locking system which are related to horizontal locking transversely of the joint edges of the boards. In practice, floorboards will be manufactured according to the inventive principles of also having locking means for mutual vertical locking of the boards.

25

Background Art

WO 94/26999 discloses a locking system for mechanical joining of building boards, especially floorboards. A mechanical locking system permits locking together of
30 the boards both perpendicular to and in parallel with the principal plane of the boards on long sides as well as short sides. Methods for making such floorboards are described in SE 9604484-7 and SE 9604483-9. The principles of designing and laying the floorboards as well

as the methods for making the same that are described in the above three documents are applicable also to the present invention, and therefore the contents of these documents are incorporated by reference in present description.

With a view to facilitating the understanding and description of the present invention as well as the understanding of the problems behind the invention, now follows with reference to Figs 1-3 a brief description of floorboards according to WO 94/26999. This description of prior art should in applicable parts be considered to apply also to the following description of embodiments of the present invention.

A floorboard 1 of known design is shown from below and from above in Figs 3a and 3b, respectively. The board is rectangular and has a top side 2, an underside 3, two opposite long sides 4a, 4b which form joint edges, and two opposite short sides 5a, 5b which form joint edges.

Both the long sides 4a, 4b and the short sides 5a, 5b can be joined mechanically without any glue in the direction D2 in Fig. 1c. To this end, the board 1 has a planar strip 6 which is mounted at the factory and which extends horizontally from one long side 4a, the strip extending along the entire long side 4a and being made of a flexible, resilient aluminium sheet. The strip 6 can be mechanically fixed according to the illustrated embodiment, or fixed by means of glue or in some other fashion. Other strip materials can be used, such as sheet of some other metal, and aluminium or plastic sections. Alternatively, the strip 6 can be integrally formed with the board 1, for instance by some suitable working of the body of the board 1. The strip, however, is always integrated with the board 1, i.e. it is not mounted on the board 1 in connection with laying. The width of the strip 6 can be about 30 mm and its thickness about 0.5 mm. A similar, although shorter strip 6' is arranged also along one short side 5a of the board 1. The edge side of the

strip 4 facing away from the joint edge 4a is formed with a locking element 8 extending along the entire strip 6. The locking element 8 has an active locking surface 10 facing the joint edge 4a and having a height of e.g. 5 0.5 mm. In connection with laying, the locking element 8 cooperates with a locking groove 14, which is formed in the underside 3 of the opposite long side 4b of an adjacent board 1'. The short side strip 6' is provided with a corresponding locking element 8', and the opposite short 10 side 5b has a corresponding locking groove 14'.

For mechanical joining of both long sides and short sides also in the vertical direction (direction D1 in Fig. 1c), the board 1 is further along its one long side 4a and its one short side 5a formed with a laterally open 15 recess 16. The recess 16 is defined downwards by the associated strip 6, 6'. At the opposite edges 4b and 5b there is an upper recess 18 defining a locking tongue 20 (see Fig. 2a) cooperating with the recess 16 to form a tongue-and-groove joint.

20 Figs 1a-1c show how two such boards 1, 1' can be joined by downwards angling. Figs 2a-2c show how the boards 1, 1' can instead be joined by snap action. The long sides 4a, 4b can be joined by both methods whereas the short sides 5a, 5b - after laying of the first row - 25 are normally joined after joining of the long sides and merely by snap action. When a new board 1' and a previously laid board 1 are to be joined along their long sides according to Figs 1a-1c, the long side 4b of the new board 1' is pressed against the long side 4a of the 30 previously laid board 1 according to Fig. 1a, so that the locking tongue 20 is inserted into the recess 16. The board 1' is then angled downwards to the subfloor 12 according to Fig. 1b. Now the locking tongue 20 completely enters the recess 16 while at the same time the locking 35 element 8 of the strip 6 enters the locking groove 14. During this downwards angling, the upper part of the locking element 8 can be active and accomplish a guiding

of the new board 1' towards the previously laid board 1. In the joined state according to Fig. 1c, the boards 1, 1' are locked in both D1 direction and D2 direction, but may be displaced relative to each other in the longitudinal direction of the joint.

Figs 2a-2c illustrate how also the short sides 5a and 5b of the boards 1, 1' can be mechanically joined in both D1 and D2 direction by the new board 1' being moved essentially horizontally towards the previously laid board 1. This can be carried out after the long side 4b of the new board 1' has been joined as described above. In the first step in Fig. 2a, bevelled surfaces adjacent to the recess 16 and the locking tongue 20 cooperate so that the strip 6' is forced downwards as a direct consequence of the joining of the short sides 5a, 5b. During the final joining, the strip 6' snaps upwards as the locking element 8' enters the locking groove 14'. By repeating the operations shown in Figs 1 and 2, the entire floor can be laid without glue and along all joint edges. Thus, prior-art floorboards of the above-mentioned type are joined mechanically by, as a rule, first being angled downwards on the long side, and when the long side is locked, the short sides are snapped together by horizontal displacement along the long side. The boards 1, 1' can be taken up again in reverse order, without the joint being damaged, and be laid once more.

For optimal function, it should be possible for the boards, after being joined, along their long sides to take a position where there is a possibility of a small play between the locking surface 10 and the locking groove 14. For a more detailed description of this play, reference is made to WO 94/26999.

In addition to the disclosure of the above-mentioned patent specifications, Norske Skog Flooring AS (licensee of Välinge Aluminium AB) introduced a laminate flooring with a mechanical joining system according to WO 94/29699 in January 1996 in connection with the Domotex fair in

Hannover, Germany. This laminate flooring marketed under the trademark Alloc[®], is 7.6 mm thick, has a 0.6 mm aluminium strip 6 which is mechanically fixed to the tongue side and the active locking surface 10 of the locking element 8 has an inclination of about 70°-80° to the plane of the board. The joint edges are impregnated with wax and the underside is provided with underlay board which is mounted at the factory. The vertical joint is designed as a modified tongue-and-groove joint. The strips 6, 6' on long side and short side are largely identical, but slightly bent upwards to different degrees on long side and short side. The inclination of the active locking surface varies between long side and short side. The distance of the locking groove 14 from the joint edge, however, is somewhat smaller on the short side than on the long side. The boards are made with a nominal play on the long side which is about 0.05-0.10 mm. This enables displacement of the long sides and bridges width tolerances of the boards. Boards of this brand have been manufactured and sold with zero play on the short sides, which is possible since the short sides need not be displaced in connection with the locking which is effected by snap action. Boards of this brand have also been made with more bevelled portions on the short side to facilitate snapping in according to Figs 2a-c above. It is thus known that the mechanical locking system can be designed in various ways and that long side and short side can be of different design.

WO 97/47834 (Unilin) discloses a mechanical joining system which is essentially based on the above known principles. In the corresponding product which this applicant began to market in the latter part of 1997, biasing between the boards is strived for. This leads to high friction and difficulties in angling together and displacing the boards. This document also shows that the mechanical locking on the short side can be designed in a manner different from the long side. In the described

embodiments, the strip is integrated with the body of the board, i.e. made in one piece with and of the same material as the body of the board.

5 Summary of the Invention

Although the flooring according to WO 94/26999 and the flooring marketed under the trademark Alloc[®] have great advantages compared with traditional, glued floorings, further improvements are desirable.

10 Mechanical joints are very suitable for joining not only laminate floorings, but also wood floorings and composite floorings. Such floorboards may consist of a large number of different materials in the surface, the core and the rear side, and as described above these materials
15 can also be included in the strip of the joining system, the locking element on the strip, fixing surfaces, vertical joints etc. This solution involving an integrated strip, however, leads to costs in the form of waste when the mechanical joint is being made. Alternatively, special materials, such as the aluminium strip 6 above, can
20 be glued or mechanically fixed to the floorboard to be included as components in the joining system. Different joint designs affect the costs to a considerable extent.

A strip made of the same material as the body of the
25 board and formed by working of the body of the board can in some applications be less expensive than an aluminium strip, especially for floorboards in lower price ranges. Aluminium, however, is more advantageous in respect of flexibility, resilience and displaceability as well as
30 accuracy in the positioning of the locking element. Aluminium also affords the possibility of making a stronger locking element. If the same strength is to be achieved with a locking element of wood fibre, it must be wide with a large shearing surface, which results in a large
35 amount of waste material in manufacture, or it must be reinforced with a binder. Depending on the size of the boards, working of, for instance, 10 mm of a joint edge

may result in six times higher cost of waste per m² of floor surface along the long sides compared with the short sides.

In addition to the above problems relating to undesirable waste of material, the present invention is based on the insight that the long sides and short sides can be optimised with regard to the specific locking functions that should be present in these joint edges.

As described above, locking of the long side is, as a rule, carried out by downwards angling. Also a small degree of bending down of the strip during locking can take place, as will be described in more detail below. Thanks to this downwards bending together with an inclination of the locking element, the boards can be angled down and up again with very tight joint edges. The locking element along the long sides should also have a high guiding capability so that the long side of a new board in connection with downwards angling is pushed towards the joint edge of the previously laid board. The locking element should have a large guiding part. For optimal function, the boards should along their long sides, after being joined, be able to take a mutual position transversely of the joint edges where there is a small play between locking element and locking groove.

On the other hand, locking of the short side is carried out by the long side being displaced so that the strip of the short side can be bent down and snap into the locking groove. Thus the short side must have means which accomplish downwards bending of the strip in connection with lateral displacement. The strength requirement is also higher on the short side. Guiding and displaceability are less important.

Summing up, there is a great need for providing a mechanical joint of the above type at a low cost and with optimal locking functions at each joint edge. It is not possible to achieve a low cost with prior-art solutions without also lowering the requirements as to strength

and/or laying function. An object of the invention is to provide solutions which aim at lowering the cost with maintained strength and function. According to the invention, these and other objects are achieved by a locking system and a floorboard having the features as defined in independent claims 1, 18, 23 and 25. Preferred embodiments are stated in the respective dependent claims.

According to a first aspect of the invention (claim 1), a locking system for mechanical joining of floorboards is thus provided, where immediately juxtaposed upper parts of two adjacent joint edges of two joined floorboards together define a joint plane perpendicular to the principal plane of the floor boards. To obtain a joining of the two joint edges perpendicular to the joint plane, the locking system comprises in a manner known per se a locking groove which is formed in the underside of and extends in parallel with the first joint edge at a distance from the joint plane, and a portion projecting from the lower part of the second joint edge and below the first joint edge and integrated with a body of the board, said projecting portion supporting at a distance from the joint plane a locking element cooperating with the locking groove and thus positioned entirely outside the joint plane seen from the side of the second joint edge, said projecting portion having a different composition of materials compared with the body of the board. The inventive locking system is characterised in that the projecting portion presents at least two horizontally juxtaposed parts, which differ from each other at least in respect of the parameters material composition and material properties.

In a first embodiment of the first aspect of the invention, said at least two parts of the projecting portion are located at different distances from the joint plane. In particular, they may comprise an inner part closest to the joint plane and an outer part at a distance from the joint plane. The inner part and the outer

part are preferably, but not necessarily, of equal length in the joint direction. In this first aspect of the invention, a material other than that included in the body is thus included in the joining system, and in particular the outer part can be at least partially formed of a separate strip which is made of a material other than that of the body of the board and which is integrally connected with the board by being factory-mounted. The inner part can be formed at least partially of a worked part of the body of the board and partially of part of said separate strip. The separate strip can be attached to such a worked part of the board body. The strip can be located entirely outside said joint plane, but can also intersect the joint plane and extend under the joint edge to be attached to the body also inside the joint plane.

This embodiment of the invention thus provides a kind of combination strip in terms of material, for example a projecting portion comprising an inner part with the material combination wood fibre/rear laminate/aluminium, and an outer part of aluminium sheet.

It is also possible to make the projecting part from three parts which are different in terms of material: an inner part closest to the joint plane, a central part and an outer part furthest away from the joint plane. The inner part and the outer part can possibly be equal in terms of material.

The portion projecting outside the joint plane need not necessarily be continuous or unbroken along the joint edge. A conceivable variant is that the projecting portion has a plurality of separate sections distributed along the joint edge. As an example, this can be accomplished by means of a separate strip with a continuous inner part and a toothed outer part, said strip being attachable to a part of the board body, said part being worked outside the joint plane.

In an alternative embodiment of the first aspect of the invention, said at least two parts, which differ in

respect of at least one of the parameters material composition and material properties, are instead juxtaposed seen in the direction parallel with the joint edges. For example, there may be a plurality of strip types on one and the same side, where each strip type is optimised for a special function, such as strength and guiding in connection with laying. As an example, the strips can be made of different aluminium alloys and/or of aluminium having different states (for instance, as a result of different types of heat treatment).

According to a second aspect of the invention (claim 18), a locking system for mechanical joining of floorboards is provided. In this second aspect of the invention, the projecting portion is instead formed in one piece with the body of the board and thus has the same material composition as the body of the board. This second aspect of the invention is characterised in that the projecting portion, as a direct consequence of machining of its upper side, presents at least two horizontally juxtaposed parts, which differ from each other in respect of at least one of the parameters material composition and material properties.

The inventive principle of dividing the projecting portion into several parts which differ from each other in terms of material and/or material properties thus is applicable also to the prior-art "wood fibre strip".

In the same manner as described above for the first aspect of the invention, these two parts can be located at different distances from the joint plane, and especially there may be three or more parts with different material composition and/or material properties. Optionally, two such parts can be equal in respect of said parameters, but they may differ from a third.

In one embodiment, said two parts may comprise an inner part closest to the joint plane and an outer part at a distance from the joint plane. There may be further parts outside the outer part. Specifically, an outer part

can be formed of fewer materials than an inner part. For instance, the inner part may consist of wood fibre and rear laminate, whereas the outer part, by machining from above, consists of rear laminate only. In one embodiment, 5 the projecting portion may comprise - seen from the joint plane outwards - an inner part, an outer part and, outside the outer part, a locking element supported by the outer part. The locking element may differ from both inner and outer part in respect of said material para- 10 meters.

The projecting portion may consist of three laminated layers, and therefore it is possible, by working from above, to provide a locking system which, counted from the top, has a relatively soft upper guiding part which 15 need not have any particular strength, a harder central part which forms a strong active locking surface and absorbs shear forces in the locking element, and a lower part which is connected with the rest of the projecting portion and which can be thin, strong and resilient.

Laminated embodiments can be suitable in such floor-boards where the body of the board consists of, for instance, plywood or particle board with several layers. Corresponding layers can be found in the walls of the locking groove. For plywood, the material properties can 25 be varied by changing the direction of fibres in the layers. For particle board, the material properties can be varied by using different chip dimensions and/or a binder in the different layers. The board body can generally consist of layers of different plastic materials.

In the definition of the invention, the term "projecting portion" relates to the part or parts of the board projecting outside the joint plane and having a function in the locking system in respect of supporting of locking element, strength, flexibility etc. 30

An underlay of underlay board, foam, felt or the like can, for instance, be mounted even in the manufacture of the boards on the underside thereof. The underlay 35

can cover the underside up to the locking element, so that the joint between the underlays will be offset relative to the joint plane F. Although such an underlay is positioned outside the joint plane, it should thus not be considered to be included in the definition of the projecting portion in the appended claims.

In the aspect of the invention which relates to embodiments with a projecting portion of the same material as the body of the board, any thin material layers which remain after working from above should in the same manner not be considered to be included in the "projecting portion" in the cases where such layers do not contribute to the locking function in respect of strength, flexibility, etc. The same discussion applies to thin glue layers, binders, chemicals, etc. which are applied, for instance, to improve moisture proofing and strength.

According to a third aspect of the invention (claim 23) there is provided a floorboard presenting a locking system according to the first aspect or the second aspect of the invention as defined above. Several possibilities of combining prior-art separate strips, prior-art wood fibre strips and "combination strips" according to the invention are available. These possibilities can be used optionally on long side and short side.

For the above aspects, the projecting portion of a given joint edge, for instance a long side, has at least two parts with different material composition and/or material properties. For optimisation of a floorboard, such a difference in materials and/or material properties, however, may be considered to exist between the long sides and short sides of the board instead of within one and the same joint edge.

According to a fourth aspect of the invention (claim 25), a rectangular floorboard is thus provided, comprising a body and first and second locking means integrated with the body and adapted to provide a mecha-

nical joining of adjacent joint edges of such floorboards along long sides and short sides, respectively, of the boards in a direction perpendicular to the respective joint edges and in parallel with the principal plane of the floorboards. According to this aspect of the invention, the floorboard is characterised in that said first and second locking means differ in respect of at least one of the parameters material composition and material properties. Preferably, said first and second locking means each comprise on the one hand a portion which projects from a joint edge and which at a distance from the joint edge supports a locking element and, on the other hand, a locking groove, which is formed in the underside of the body at an opposite joint edge for engaging such a locking element of an adjacent board. At least one of said locking means on the long side and the short side may comprise a separate element which is integrally fixed to the body of the board at the factory and is made of a material other than that included in the body of the board. The other locking means may comprise an element which is formed in one piece with the body of the board.

Within the scope of the fourth aspect of the invention, there are several possibilities of combination. For example, it is possible to select an aluminium strip for the long side and a machined wood fibre strip for the short side or vice versa. Another example is that for the short side or the long side a "combination strip" according to the first and the second aspect of the invention is selected, and for the other side a "pure" aluminium strip or a "pure" worked wood fibre strip is selected.

The above problem of undesirable costs of material is solved according to the invention by the projecting portion being made of different materials and/or material combinations and thus specially adaptable to the selected materials in the floorboard and the function and strength

requirements that apply to the specific floorboard and that are specific for long side and short side. This advantage of the invention will be evident from the following description.

5 Since different requirements are placed on the long side and the short side and also the cost of waste differs, improvements can also be achieved by the long side and the short side being made of different materials or combinations of materials. In some applications, the long
10 side can have, for instance, an aluminium strip with high guiding capability and low friction whereas the short side can have a wood fibre strip. In other applications, the opposite is advantageous.

 In some applications, there may also be a need for
15 different types of strip on the same side. The side may consist of, for instance, a plurality of different strips which are made of different aluminium alloys, have different thicknesses etc. and in which certain parts are intended to achieve high strength and others are intended
20 to be used for guiding.

 Different aspects of the invention will now be described in more detail by way of examples with reference to the accompanying drawings. The parts of the inventive board which are equivalent to those of the
25 prior-art board in Figs 1-3 are provided with the same reference numerals.

Brief Description of the Drawings

 Figs 1a-c illustrate in three steps a downwards
30 angling method for mechanical joining of long sides of floorboards according to WO 94/26999.

 Figs 2a-c illustrate in three steps a snap-in method for mechanical joining of short sides of floorboards according to WO 94/26999.

35 Figs 3 and 3b show a floorboard according to WO 94/26999 seen from above and from below, respectively.

Fig. 4 shows a floorboard with a locking system according to a first embodiment of the invention.

Fig. 5 is a top plan view of a floorboard according to Fig. 4.

5 Fig. 6a shows on a larger scale a broken-away corner portion C1 of the board in Fig. 5, and Figs 6b and 6c are vertical sections of the joint edges along the long side 4a and the short side 5a of the board in Fig. 5, from which it is particularly evident that the long side and
10 the short side are different.

Figs 7a-c show a downwards angling method for mechanical joining of long sides of the floorboard according to Figs 4-6.

Fig. 8 shows two joined floorboards provided with
15 a locking system according to a second embodiment of the invention.

Fig. 9 shows two joined floorboards provided with a locking system according to a third embodiment of the invention.

20 Figs 10-12 illustrate three different embodiments of floorboards according to the invention where the projecting portion is formed in one piece with the body of the board.

25 Description of Preferred Embodiments

A first preferred embodiment of a floorboard 1 provided with a locking system according to the invention will now be described with reference to Figs 4-7. The shown example also illustrates the aspect of the invention which concerns differently designed locking systems
30 for long side and short side.

Fig. 4 is a cross-sectional view of a long side 4a of the board 1. The body of the board 1 consists of a core 30 of, for instance, wood fibre which supports a
35 surface laminate 32 on its front side and a balance layer 34 on its rear side. The board body 30-34 is rectangular with long sides 4a, 4b and short sides 5a, 5b. A separate

strip 6 with a formed locking element 8 is mounted at the factory on the body 30-34, so that the strip 6 constitutes an integrated part of the completed floorboard 1. In the shown example, the strip 6 is made of resilient aluminium sheet. As an illustrative, non-limiting example, the aluminium sheet can have a thickness in the order of 0.6 mm and the floorboard a thickness in the order of 7 mm. For further description of dimensions, possible materials, etc. for the strip 6, reference is made to the above description of the prior-art board.

The strip 6 is formed with a locking element 8, whose active locking surface 10 cooperates with a locking groove 14 in an opposite joint edge 4b of an adjacent board 1' for horizontal locking together of the boards 1, 1' transversely of the joint edge (D2). With a view to forming a vertical lock in the D1 direction, the joint edge 4a has a laterally open groove 36 and the opposite joint edge 4b has a laterally projecting tongue 38 (corresponding to the locking tongue 20), which in the joined state is received in the groove 36 (Fig. 7c). The free surface of the upper part 40 of the groove 36 has a vertical upper portion 41, a bevelled portion 42 and an upper abutment surface 43 for the tongue 38. The free surface of the lower part 44 of the groove 36 has a lower abutment surface 45 for the tongue 38, a bevelled portion 46 and a lower vertical portion 47. The opposite joint edge 4b (see Fig. 7a) has an upper vertical portion 48, and the tongue 38 has an upper abutment surface 49, an upper bevelled portion 50, a lower bevelled portion 51 and a lower abutment surface 52.

In the joined state (Fig. 7c), the two juxtaposed vertical upper portions 41 and 48 define a vertical joint plane F. As is best seen from Fig. 4, the lower part 44 of the groove 36 is extended a distance outside the joint plane F. The joint edge 4a is in its underside formed with a continuous mounting groove 54 having a vertical lower gripping edge 56 and an inclined gripping edge 58.

The gripping edges formed of the surfaces 46, 47, 56, 58 together define a fixing shoulder 60 for mechanical fixing of the strip 6. The fixing is carried out according to the same principle as in the prior-art board and can
5 be carried out by means of the methods that are described in the above-mentioned documents. A continuous lip 62 of the strip 6 thus is bent round the gripping edges 56, 58 of the groove 54, while a plurality of punched tongues 64 are bent round the surfaces 46, 47 of the projecting portion 44. The tongues 64 and the associated punched holes
10 65 are shown in the broken-out view in Fig. 6a.

There is a significant difference between the inventive floorboard shown in Figs 4-7 and the prior-art board according to Figs 1-3. The area P in Fig. 4 designates
15 the portion of the board 1 which is positioned outside the joint plane 1. According to the invention, the portion P has two horizontally juxtaposed parts P1 and P2, which differ in respect of at least one of the parameters material composition and material properties. More speci-
20 fically, the inner part P1 is, closest to the joint plane F, formed partially of the strip 6 and partially of the worked part 44 of the body. In this embodiment, the inner part P1 thus comprises the material combination aluminium + wood fibre core + rear laminate whereas the
25 outer part P2 is a made of aluminium only. In the prior-art board 1 in Figs 1a-c, the corresponding portion outside the joint plane is made of aluminium only.

As described above, this feature of the invention means that the cost of material can be reduced. Thanks to
30 the fact that the fixing shoulder 60 is displaced towards the locking element 8 to such an extent that it is positioned at least partially outside the joint plane F, a considerable saving can be achieved in respect of the consumption of aluminium sheet. A saving in the order of
35 25% is possible. This embodiment is particularly advantageous in cheaper floorboards where waste of wood fibre as a result of machining of the body is preferred to a

high consumption of aluminium sheet. The waste of material, however, is limited thanks to the fact that the projecting portion can also be used as abutment surface for the tongue, which can then be made correspondingly narrower perpendicular to the joint plane with the ensuing reduced waste of material on the tongue side.

This constructional change to achieve saving in material does not have a detrimental effect on the possibility of resilient vertical motion that must exist in the projecting portion P. The strength of the locking element 8 is not affected either. The outer part P2 of aluminium is still fully resilient in the vertical direction, and the short sides 5a, 5b can be snapped together according to the same principle as in Figs 2a-c. The locking element 8 is still made of aluminium and its strength is not reduced. However, it may be noted that the degree of resilience can be affected since it is essentially only the outer part P2 that is resilient in the snap action. This can be an advantage in some cases if one wants to restrict the bending-down properties and increase the strength of the lock.

The angling together of the long sides 4a, 4b can also be carried out according to the same principle as in Figs 1a-c. In general - not only in this embodiment - a small degree of downwards bending of the strip 6 may occur, as shown in the laying sequence in Figs 7a-c. This downwards bending of the strip 6 together with an inclination of the locking element 8 makes it possible for the boards 1, 1' to be angled down and up again with very tight joint edges at the upper surfaces 41 and 48. The locking element 8 should preferably have a high guiding capability so that the boards, in connection with downwards angling, are pushed towards the joint edge. The locking element 8 should have a large guiding part. For optimal function, the boards should, after being joined and along their long sides 4a, 4b, be able to take a position where there is a small play between locking ele-

ment and locking groove, which need not be greater than about 0.02-0.05 mm. This play permits displacement and bridges width tolerances. The friction in the joint should be low.

5 In the joined state according to Fig. 7c, the boards 1, 1' are locked relative to each other in the vertical direction D1. An upwards movement of the board 1' is counteracted by engagement between the surfaces 43 and 49, while a downwards movement of the board 1' is coun-
10 teracted on the one hand by engagement between the surfaces 45 and 52 and, on the other hand, by the board 1 resting on the upper side of the strip 6.

Fig. 8 shows a second embodiment of the invention. The board 1 in Fig. 8 can be used for parquet flooring.
15 The board 1 consists of an upper wear layer 32a, a core 30 and a rear balance layer 34a. In this embodiment, the projecting portion P outside the joint plane F is to a still greater extent made of different combinations of materials. The locking groove 14 is reinforced by the use
20 of a separate component 70 of, for instance, wood fibre, which in a suitable manner is connected with the joint edge, for instance by gluing. This variant can be used, for instance, on the short side 5b of the board 1. Moreover, a large part of the fixing shoulder 60 is position-
25 ed outside the joint plane F.

Fig. 9 shows a third embodiment of the invention. The board 1 in Fig. 9 is usable to provide a strong attachment of the aluminium strip 6. In this embodiment, a separate part 72 is arranged on the joint edge support-
30 ing the locking element 8. The part 72 can be made of, for instance, wood fibre. The entire fixing shoulder 60 and the entire strip 6 are located outside the joint plane F. Only a small part of the separate strip 6 is used for resilience. From the viewpoint of material, the
35 portion P located outside the joint plane F has three different areas containing the combinations of materials "wood fibre only" (P1), "wood fibre/balance layer/alumi-

nium" (P2) and "aluminium only" (P3). This embodiment with the fixing shoulder 6 positioned entirely outside the joint plane F can also be accomplished merely by working the body of the board, i.e. without the separate
5 part 72. The embodiment in Fig. 9 can be suitable for the long side. The locking element 8 has a large guiding part, and the projecting portion P outside the joint plane F has a reduced bending down capability.

When comparing the embodiments in Figs 8 and 9, it
10 may be noted that in Fig. 9 the tongues 64 are higher than the lip 62. This results in a strong attachment of the strip 6 in the front edge of the fixing shoulder 60, which is advantageous when bending down the strip 6. This can be achieved without any extra cost of material since
15 the tongues 64 are punched from the existing material. On the other hand, the lip 62 can be made lower, which is advantageous in respect of on the one hand consumption of material and, on the other hand, the weakening effect of the mounting groove 54 on the joint edge. It should fur-
20 ther be noted that the locking element 8 in Fig. 8 is lower, which facilitates the snapping in on the short sides.

Figs 10-12 show three different embodiments of the invention, in which the projecting portion can be made
25 in one piece with the board body or consists of separate materials which are glued to the edge of the board and are machined from above. Separate materials are particularly suitable on the short side where strength and resili-
30 ence requirements are high. Such an embodiment means that the composition of materials on the long side and the short side can be different.

The above technique of providing the edge of the body, on the long side and/or short side, with separate materials that are fixed to the body to achieve special
35 functions, such as strength, moisture proofing, flexibility etc, can be used also without utilising the principles of the invention. In other words, it is possible

also in other joining systems, especially mechanical joining systems, to provide the body with separate materials in this way. In particular, this material can be applied as an edge portion, which in some suitable
5 fashion is attached to the edge of the body and which can extend over the height of the entire board or parts thereof.

In a preferred embodiment, the edge portion is applied to the body before the body is provided with all
10 outer layers, such as top layer and rear balance layer. Especially, such layers can then be applied on top of the fixed, separate edge portion, whereupon the latter can be subjected to working in respect of form with a view to forming part of the joining system, such as the project-
15 ing portion with locking element and/or the tongue with locking groove.

In Figs 10 and 11, the board body is composed of a top laminate 32, a wood fibre core 30 and a rear laminate 34. The locking element 8 is formed by the project-
20 ing portion P being worked from above in such manner that, seen from the joint plane F outwards, it has an inner part P1 consisting of wood fibre 30 and laminate 34, a central part P2 consisting of laminate 34 only, and an outer part P3 consisting of wood fibre and laminate
25 34.

The embodiments in Figs 10 and 11 differ from each other owing to the fact that in Fig. 10 the boundary between the wood fibre core 30 and the rear laminate 34 is on a vertical level with the lower edge of the active
30 locking surface 10. Thus, in Fig. 10 no significant working of the rear laminate 34 has taken place in the central part P2. On the other hand, in Fig. 11 also the rear laminate 34 has been worked in the central part P2, which gives the advantage that the active locking surface 10
35 of the locking element 8 is wholly or partly made of a harder material.

The embodiment in Fig. 12 differs from the embodiments in Figs 10 and 11 by an additional intermediate layer 33 being arranged between the wood fibre core 30 and the rear laminate 34. The intermediate layer 33 should be relatively hard and strong to reinforce the active locking surface 10 as shown in Fig. 12. For example, the immediate layer 33 can be made of a separate material which is glued to the inner core. Alternatively, the immediate layer 33 may constitute a part of, for instance, a particle board core, where chip material and binder have been specially adapted to the mechanical joining system. In this alternative, the core and the intermediate layer 33 can thus both be made of chip material, but with different properties. The layers can be optimised for the different functions of the locking system.

Moreover, the aspects of the invention including a separate strip can preferably be implemented in combination with the use of an equalising groove of the type described in WO 94/26999. Adjacent joint edges are equalised in the thickness direction by working of the underside, so that the upper sides of the floorboards are flush when the boards are joined. Reference letter E in Fig. 1a indicates that the body of the boards after such working has the same thickness in adjacent joint edges. The strip 6 is received in the groove and will thus be partly flush-mounted in the underside of the floor. A corresponding arrangement can thus be accomplished also in combination with the invention as shown in the drawings.

CLAIMS

1. A locking system for mechanical joining of floor-
5 boards (1, 1'), in which immediately juxtaposed upper
parts (41, 48) of two adjacent joint edges (4a, 4b; 5a,
5b) of two joined floorboards (1, 1') together define a
joint plane (F) perpendicular to the principal plane of
the floorboards, said locking system for providing a
10 joining of the two joint edges (4a, 4b; 5a, 5b) perpendi-
cular to the joint plane (F) comprising a locking groove
(14) which is formed in the underside (3) of and extends
in parallel with the first joint edge (4b, 5b) at a dis-
tance from the joint plane (F) and a portion (P) project-
15 ing from the lower part of the second joint edge (4a, 5a)
and below the first joint edge (4b, 5b) and integrated
with a body (30, 32, 34) of the board (1), said project-
ing portion (P) supporting at a distance from the joint
plane (F) a locking element (8) cooperating with the
20 locking groove (14), said projecting portion (P) thus
being located entirely outside the joint plane (F) seen
from the side of the second joint edge, and said project-
ing portion (P) having a material composition other than
that of the body of the board, c h a r a c t e r i s e d
25 in that the projecting portion (P) presents at least two
horizontally juxtaposed parts (P1, P2), which differ from
each other in respect of at least one of the parameters
material composition and material properties.

2. A locking system as claimed in claim 1, wherein
30 said at least two parts (P1, P2) are located at different
distances from the joint plane (F).

3. A locking system as claimed in claim 2, wherein
said parts (P1, P2) comprise an inner part (P1) closest
to the joint plane (F) and an outer part (P2) at a dis-
35 tance from the joint plane (F).

4. A locking system as claimed in claim 3, wherein
the outer part (P2) is at least partially formed of a

separate strip (6, 6'), which is made of a material different from that of the body of the board and which is integrally connected with the board by being factory-mounted.

5 5. A locking system as claimed in claim 3 or 4, wherein the inner part (P1) is formed at least partially of a worked part (44) of the body of the board.

6. A locking system as claimed in claims 4 and 5, wherein the inner part (P1) is formed at least on the one
10 hand of said worked part (44) of the body of the board and, on the other hand, of a part of said separate strip (6, 6').

7. A locking system as claimed in claim 5, wherein the inner part (P1) is formed merely of a worked part of
15 the body of the board.

8. A locking system as claimed in any one of claims 5-7, wherein said locking system, for providing a joining of the two joint edges (4a, 4b; 5a, 5b) also perpendicular (D1) to the principal plane of the boards (1, 1'),
20 comprises a tongue-and-groove joint (36, 38) with a tongue (38) at the first joint edge (4b, 5b) and a groove (36) at the second joint edge (4a, 5a), said worked part (44) of the body of the board included in the inner part (P1) constituting an extension of the lower part of the
25 groove (36).

9. A locking system as claimed in claim 6, wherein the strip (6, 6') is attached (64) to said worked part (44) of the body of the board.

10. A locking system as claimed in claim 6, wherein
30 the strip (6) intersects the joint plane (F) and extends under said second joint edge (4a, 5a).

11. A locking system as claimed in claim 10, wherein the strip (6) is attached to the body of the board inside the joint plane (F).

35 12. A locking system as claimed in any one of claims 6-9, wherein the strip (6) is located entirely outside the joint plane (F).

13. A locking system as claimed in any one of claims 4-12, wherein the strip (6) is mechanically attached (60, 62, 64).

14. A locking system as claimed in any one of claims 5 3-13, wherein the outer part (P2) is resilient in the direction (D1) transversely of the principal plane of boards.

15. A locking system as claimed in any one of claims 1-14, wherein the portion (P) projecting outside the joint plane (F) is extended continuously along essentially the entire length of said second joint edge (4a, 5a).

16. A locking system as claimed in any one of claims 1-15, wherein the portion (P) projecting outside the joint plane (F) has a plurality of separate sections distributed along said second joint edge (4a, 5a).

17. A locking system as claimed claim 1, wherein said at least two parts are juxtaposed in a direction parallel with the joint edges.

18. A locking system for mechanical joining of floorboards (1), in which immediately juxtaposed upper parts (41, 48) of two adjacent joint edges (4a, 4b; 5a, 5b) of two joined floorboards (1, 1') together define a joint plane (F) perpendicular to the principal plane of the floor surfaces, wherein said locking system, for providing a joining of the two joint edges perpendicular (D2) to the joint plane (F), comprises a locking groove (14) which is formed in the underside (3) of and extends in parallel with the first joint edge (4b, 5b) at a distance from the joint plane (F), and a portion (P) projecting from the lower part of the second joint edge (4a, 5a) and below the first joint edge (4b, 5b), said projecting portion (P) being formed in one piece with a body (30, 32, 34) of the board (1) and supporting a locking element (8) at a distance from the joint plane (F), said projecting portion (P) thus being located completely outside the joint plane (F), characterized in that the projecting portion (P), as a direct consequence

of machining of its upper side, presents at least two horizontally juxtaposed parts (P1, P2), which differ from each other in respect of at least one of the parameters material composition and material properties.

5 19. A locking system as claimed claim 18, wherein said at least two parts (P1, P2) are located at different distances from the joint plane (F).

20. A locking system as claimed in claim 19, wherein said at least two parts comprise an inner part (P1)
10 closest to the joint plane (F) and an outer part (P2) at a distance from the joint plane (F).

21. A locking system as claimed in claim 20, wherein the inner part (P2) and the outer part (P3) are limited by a vertical plane which essentially coincides with an
15 active locking surface (10), cooperating with the locking groove, of the locking element (8).

22. A locking system as claimed in any one of claims 19-21, wherein said at least two parts comprise three or more parts (P1, P2, P3) located at different distances
20 from the joint plane (F).

23. A floorboard (1) provided with a locking system according to any one of the preceding claims.

24. A floorboard (1) as claimed in claim 23, which has opposite long sides (4a, 4b) and short sides (5a, 5b)
25 and which is mechanically joinable along its long sides (4a, 4b) with long sides of identical floorboards by downwards angling and which is mechanically joinable along its short sides (5a, 5b) with short sides of identical floorboards by displacement along said long sides
30 (4a, 4b).

25. A rectangular floorboard (1) comprising a body (30, 32, 34) and first and second locking means (6, 8, 14; 6', 8', 14') integrated with the body and adapted to provide mechanical joining of adjacent joint edges (4a, 4b; 5a, 5b) of such floorboards (1, 1') along the long
35 sides (4a, 4b) and short sides (5a, 5b), respectively, of the boards in a direction (D2) perpendicular to the

respective joint edges and in parallel with the principal plane of the floorboards, characterised in that said first and second locking means (6, 8, 14; 6', 8', 14') differ from each other in respect of at least one of the parameters material composition and material properties, and that at least one of said locking means at the long side and short side comprises a separate element (6, 6') which is integrally connected with the body of the board at the factory and is made of a material other than that included in the body of the board.

26. A rectangular floorboard (1) comprising a body (30, 32, 34) and first and second locking means (6, 8, 14; 6', 8', 14') integrated with the body and adapted to provide mechanical joining of adjacent joint edges (4a, 4b; 5a, 5b) of such floorboards (1, 1') along long sides (4a, 4b) and short sides (5a, 5b), respectively, of the boards in a direction (D2) perpendicular to the respective joint edges and in parallel with the principal plane of the floorboards, characterised in that said first and second locking means (6, 8, 14; 6', 8', 14') differ from each other in respect of at least one of the parameters material composition and material properties, and that at least one of said locking means at the long side and short side comprises an element which is formed in one piece with the body of the board.

27. A floorboard as claimed in claim 25 or 26, wherein said first and second locking means (6, 8, 14; 6', 8', 14') each comprise on the one hand a portion (P) projecting from a joint edge (4a, 5a) and, at a distance from the joint edge, supporting a locking element (8, 8') and, on the other hand, a locking groove (14, 14') which is formed in the underside (3) of the body at an opposite joint edge (4b, 5b) for engagement with such a locking element of an adjacent board.

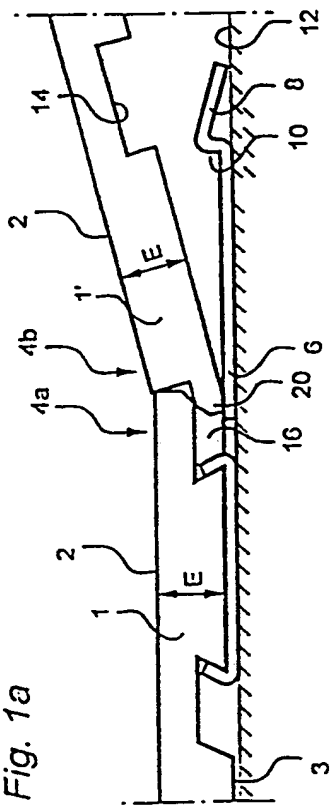

Fig. 2a

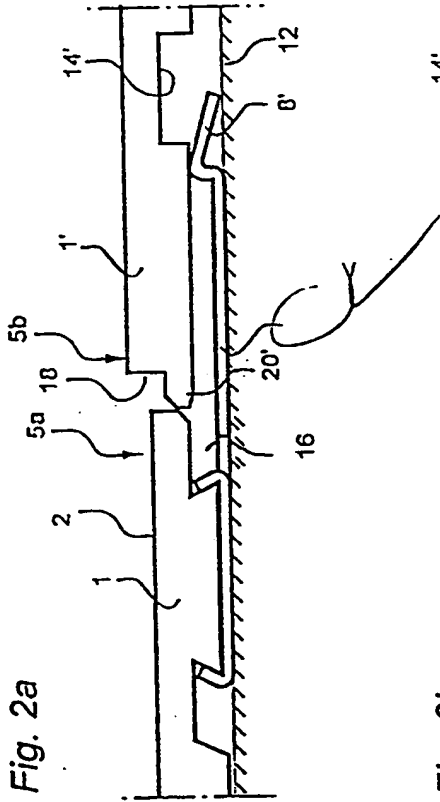

Fig. 2b

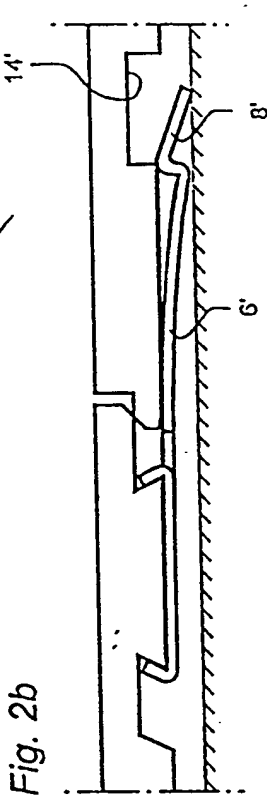

Fig. 1c

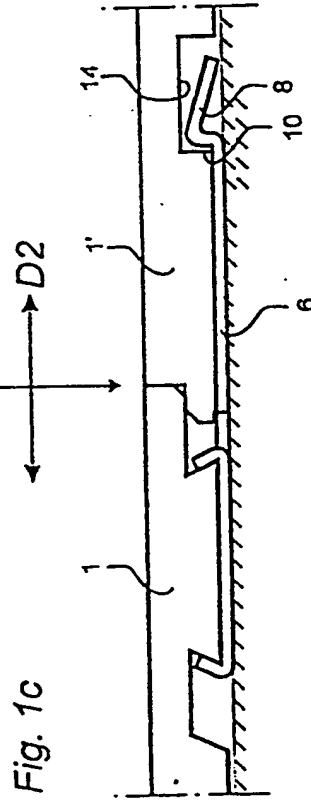

Fig. 1b

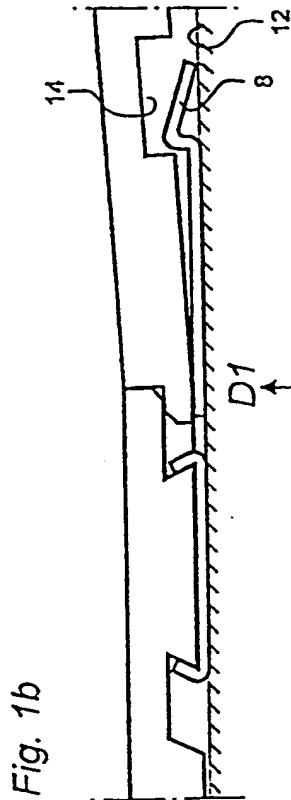
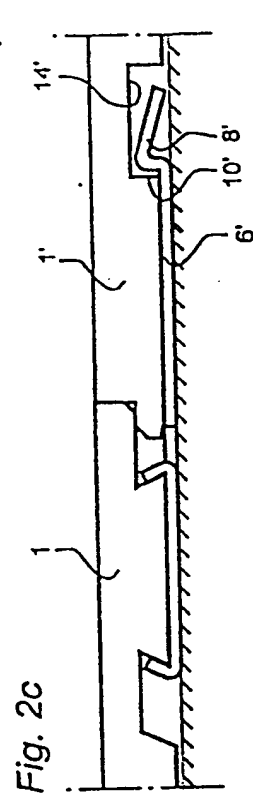

Fig. 2c



PRIOR-ART TECHNIQUE

PRIOR-ART TECHNIQUE

Fig. 3a

Fig. 3b

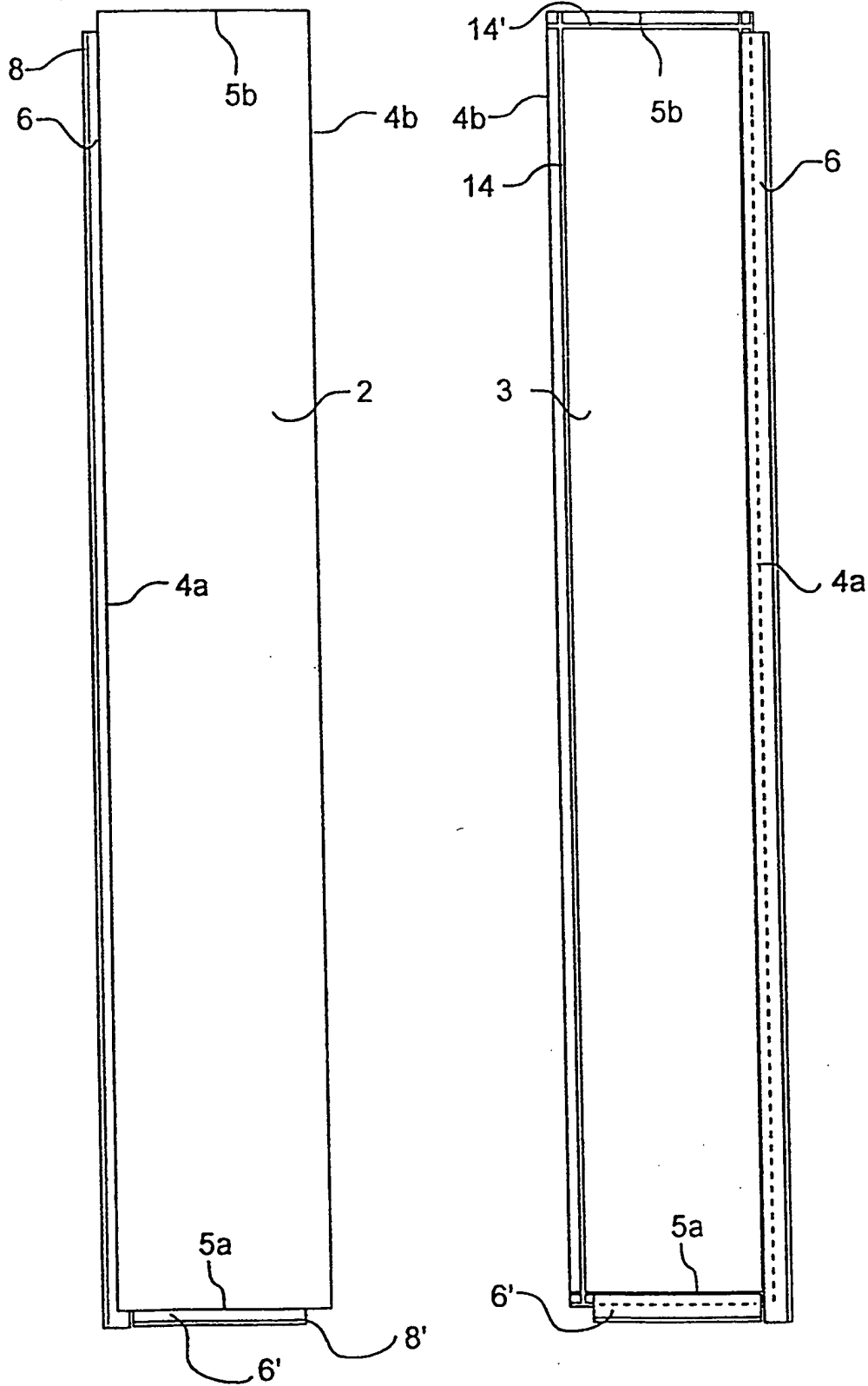

PRIOR-ART TECHNIQUE

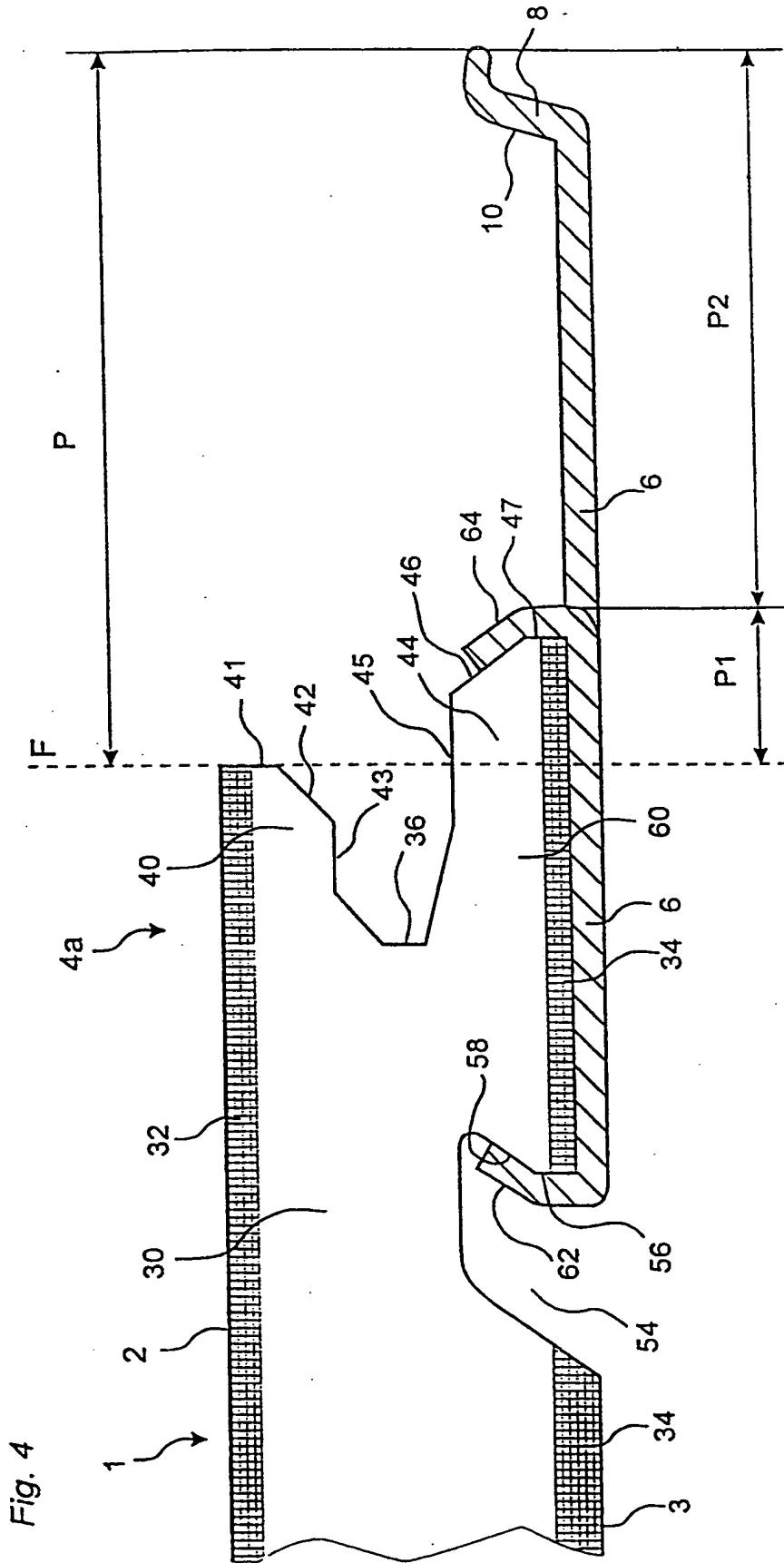

4/7

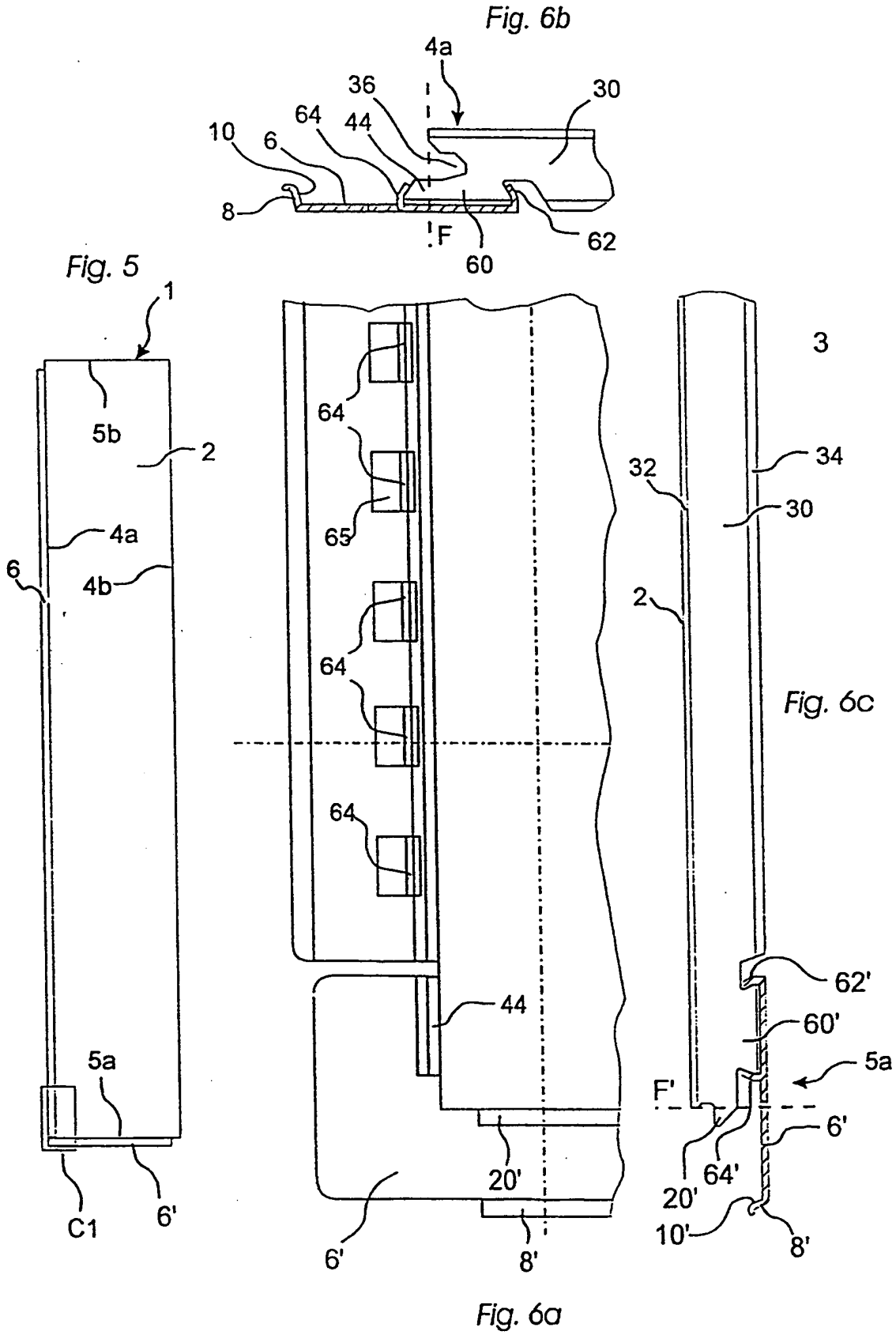

5/7

Fig. 7a

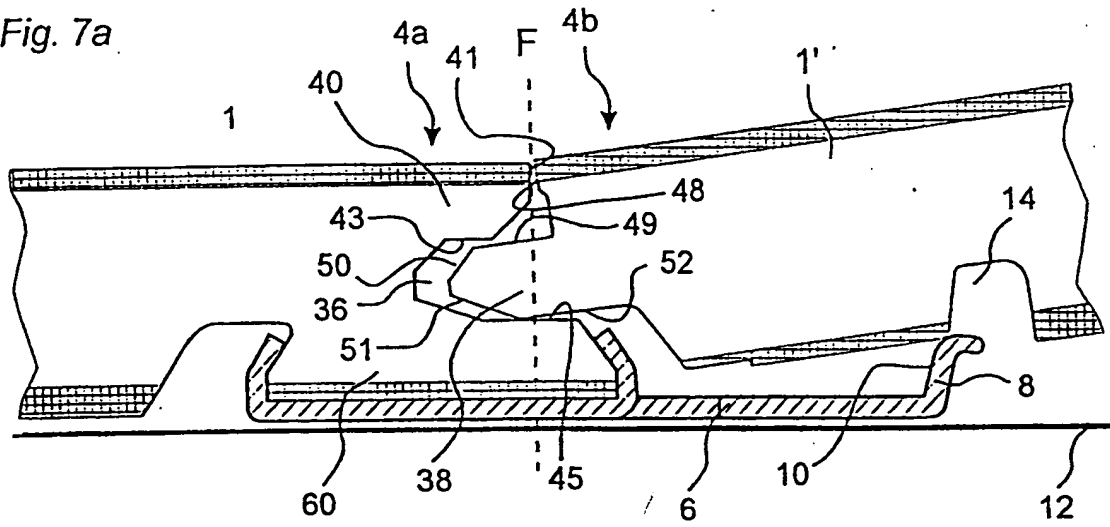

Fig. 7b

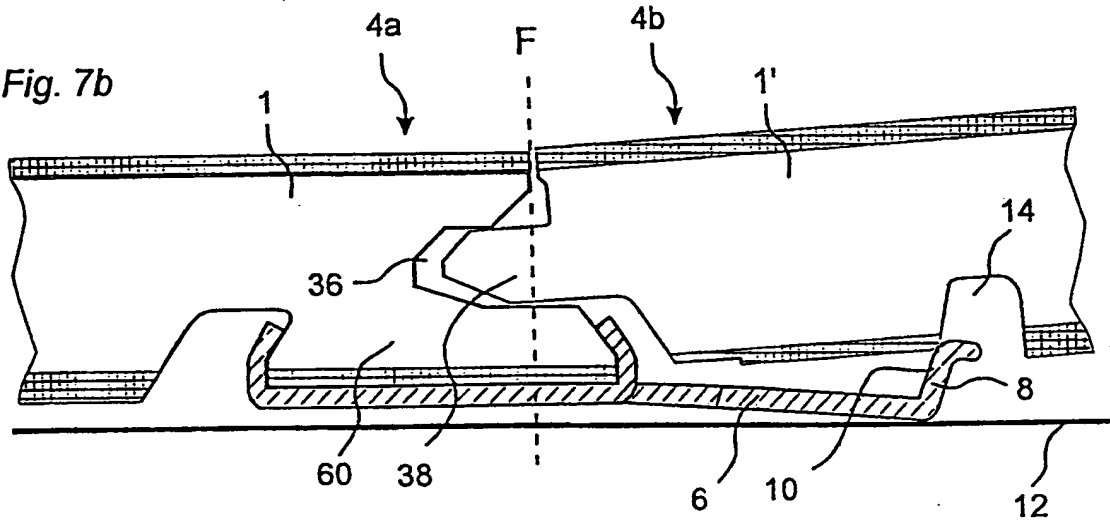

Fig. 7c

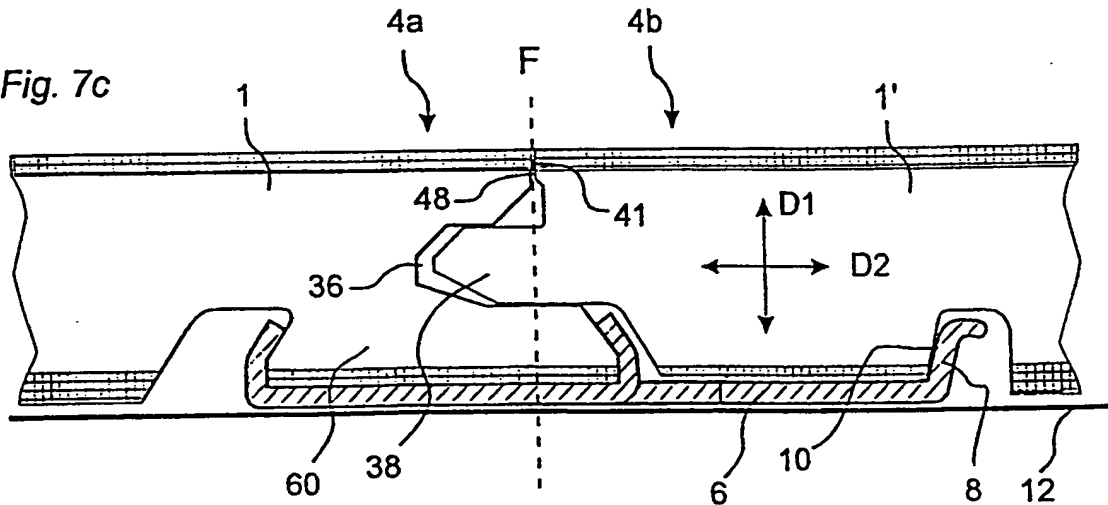

Fig. 8

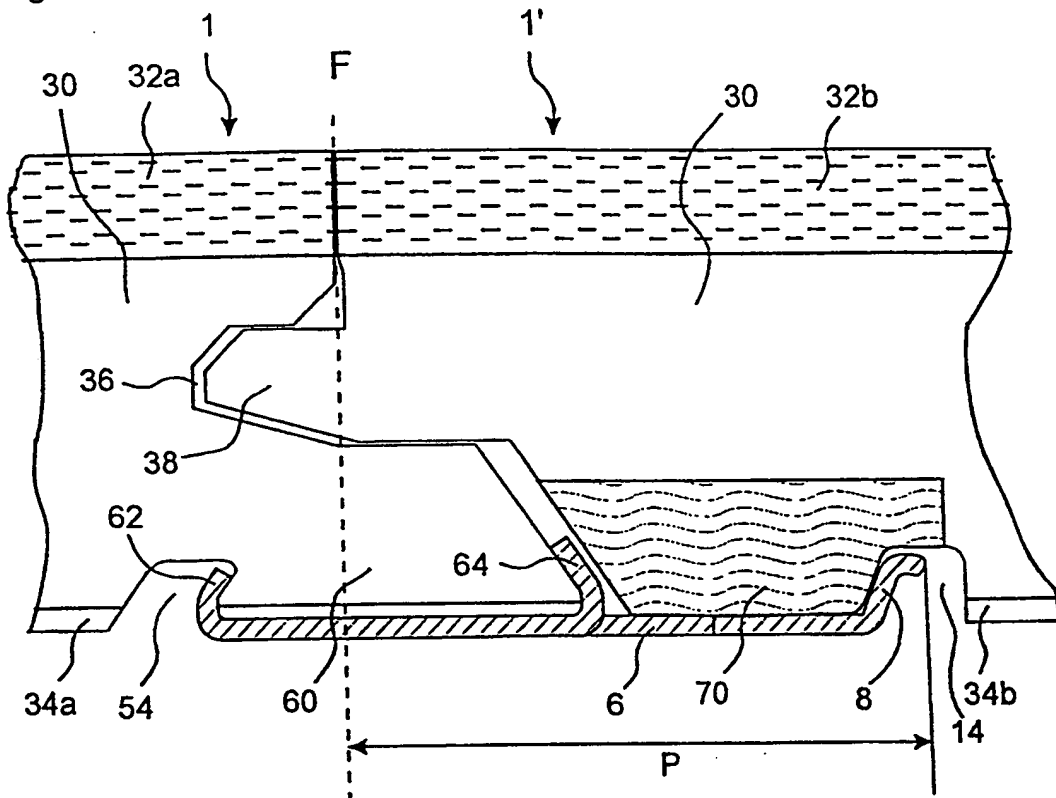
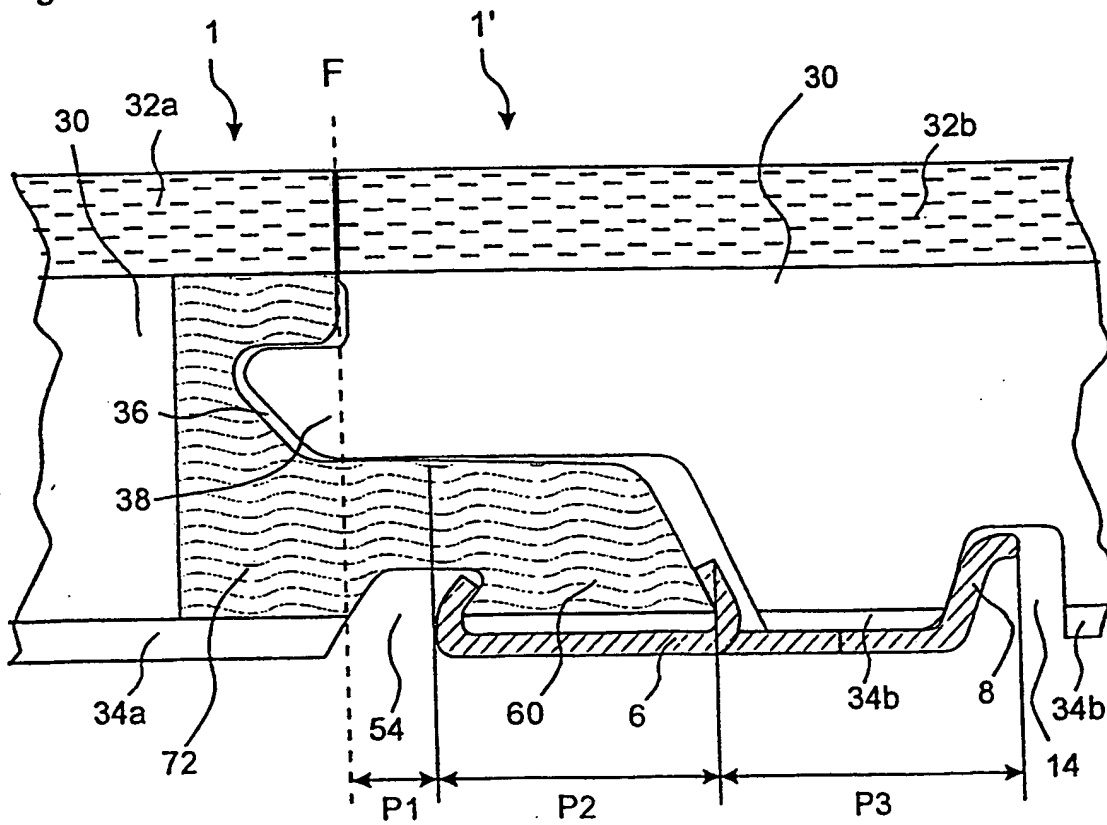
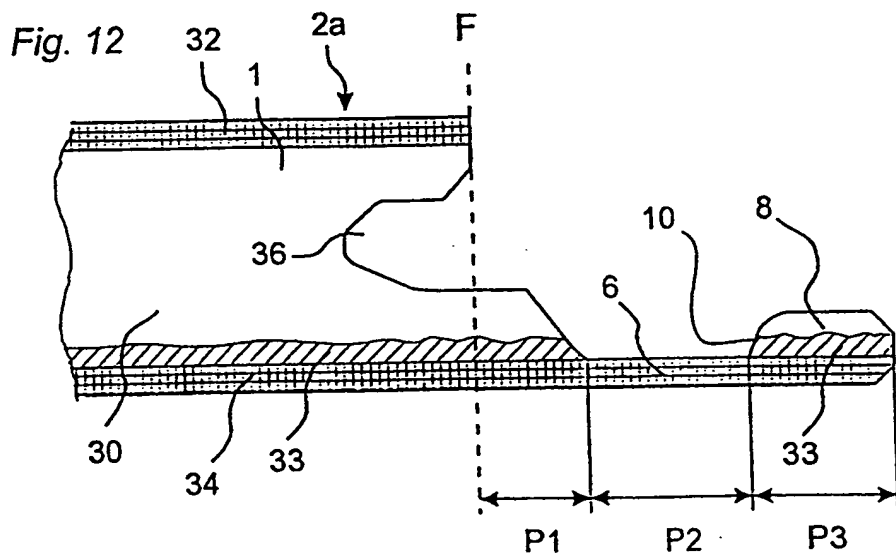
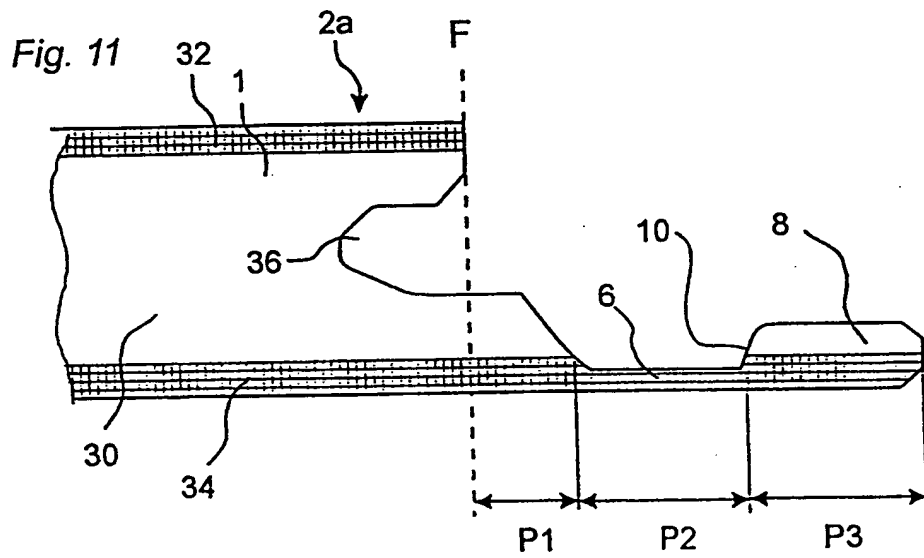
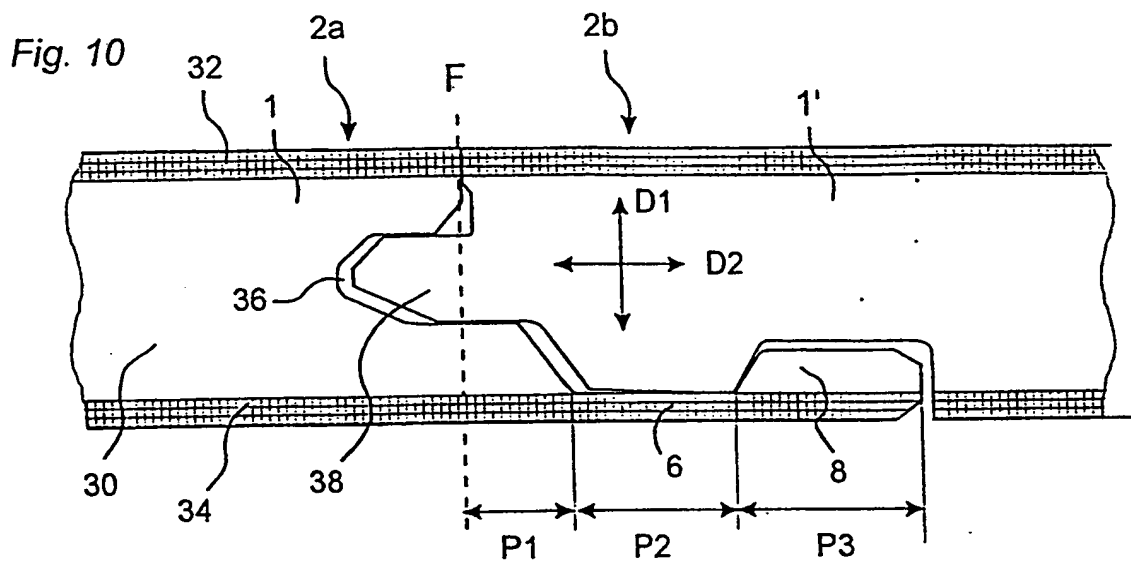

Fig. 9



7/7



INTERNATIONAL SEARCH REPORT

International application No.

PCT/SE 99/00934

A. CLASSIFICATION OF SUBJECT MATTER

IPC6: E04F 15/04

According to International Patent Classification (IPC) or to both national classification and IPC

B. FIELDS SEARCHED

Minimum documentation searched (classification system followed by classification symbols)

IPC6: E04F

Documentation searched other than minimum documentation to the extent that such documents are included in the fields searched

SE,DK,FI,NO classes as above

Electronic data base consulted during the international search (name of data base and, where practicable, search terms used)

C. DOCUMENTS CONSIDERED TO BE RELEVANT

Category*	Citation of document, with indication, where appropriate, of the relevant passages	Relevant to claim No.
A	EP 0652340 A1 (GERAUD, P.), 10 May 1995 (10.05.95), details 20,21,13,17 --	25-27
A	WO 9426999 A1 (VÄLINGE ALUMINIUS AB), 24 November 1994 (24.11.94) --	1-27
A	WO 9627719 A1 (PERSTORP FLOORING AB), 12 Sept 1996 (12.09.96), figure 3, abstract --	1-27
A	WO 9627721 A1 (PERSTORP FLOORING AB), 12 Sept 1996 (12.09.96), figure 3, abstract --	1-27

 Further documents are listed in the continuation of Box C. See patent family annex.

* Special categories of cited documents:

- "A" document defining the general state of the art which is not considered to be of particular relevance
- "E" other document but published on or after the international filing date
- "L" document which may throw doubts on priority claims) or which is cited to establish the publication date of another citation or other special reason (as specified)
- "O" document referring to an oral disclosure, use, exhibition or other means
- "P" document published prior to the international filing date but later than the priority date claimed

"T" later document published after the international filing date or priority date and not in conflict with the application but cited to understand the principle or theory underlying the invention

"X" document of particular relevance: the claimed invention cannot be considered novel or cannot be considered to involve an inventive step when the document is taken alone

"Y" document of particular relevance: the claimed invention cannot be considered to involve an inventive step when the document is combined with one or more other such documents, such combination being obvious to a person skilled in the art

"&" document member of the same patent family

Date of the actual completion of the international search

30 Sept 1999

Date of mailing of the international search report

11-10-1999

Name and mailing address of the ISA
Swedish Patent Office

Authorized officer

INTERNATIONAL SEARCH REPORT

International application No.

PCT/SE 99/00934

C (Continuation). DOCUMENTS CONSIDERED TO BE RELEVANT

Category*	Citation of document, with indication, where appropriate, of the relevant passages	Relevant to claim No.
A	WO 9447834 A1 (UNILIN BEHEER B.V.), 18 December 1997 (18.12.97), abstract ----- --	1-27

INTERNATIONAL SEARCH REPORT
Information on patent family members

30/08/99

International application No.

PCT/SE 99/00934

Patent document cited in search report	Publication date	Patent family member(s)	Publication date
EP 0652340 A1	10/05/95	FR 2712329 A,B	19/05/95
WO 9426999 A1	24/11/94	AT 171238 T	15/10/98
		AU 671919 B	12/09/96
		AU 6763094 A	12/12/94
		BG 61457 B	29/08/97
		BG 100126 A	28/06/96
		BR 9406718 A	06/02/96
		CA 2150384 A	24/11/94
		CN 1122623 A	15/05/96
		CZ 9502852 A	15/05/96
		DE 69413391 D,T	04/02/99
		EP 0698162 A,B	28/02/96
		SE 0698162 T3	
		EP 0855482 A	29/07/98
		EP 0877130 A	11/11/98
		ES 2122280 T	16/12/98
		FI 951211 A	15/03/95
		HU 75843 A	28/05/97
		HU 214470 B	30/03/98
		HU 9503216 D	00/00/00
		JP 8510022 T	22/10/96
		LV 11491 A,B	20/08/96
		NO 305614 B	28/06/99
		NO 950790 A	22/05/95
		NO 986137 A	22/05/95
		NO 993136 A	24/06/99
		NZ 266232 A	26/11/96
		PL 311568 A	19/02/96
		SE 501014 C	17/10/94
		SE 9301595 A	17/10/94
		SG 47518 A	17/04/98
		SK 141195 A	06/11/96
		US 5706621 A	13/01/98
		US 5860267 A	19/01/99
WO 9627719 A1	12/09/96	AU 2941495 A	25/01/96
		AU 5017696 A	23/09/96
		EP 0730435 A	11/09/96
		JP 9502639 T	18/03/97
		SE 502994 C,E	04/03/96
		SE 9500809 A	04/03/96
		US 5779477 A	14/07/98
WO 9627721 A1	12/09/96	AU 4960096 A	23/09/96
		BR 9607272 A	23/06/98
		CA 2213757 A	12/09/96
		CN 1177390 A	25/03/98
		EP 0768929 A,B	23/04/97
		EP 0813641 A	29/12/97
		JP 10502303 T	03/03/98
		JP 11501377 T	02/02/99
		NO 974110 A	06/11/97
		SE 9500810 D	00/00/00
		US 5897272 A	27/04/99

INTERNATIONAL SEARCH REPORT
Information on patent family members

30/08/99

International application No.
PCT/SE 99/00934

Patent document cited in search report	Publication date	Patent family member(s)	Publication date
---	---------------------	----------------------------	---------------------

WO 9447834 A1 18/12/97 NONE
